

# Earth First!

☞ Climbers Guild ☞



VOL. 3

TRAINING, SET UPS, TRAVERSES, SAFETY FACTOR,  
HAUL SYSTEMS, AND BASIC RESCUE

## **Vol. 3 Training set ups, Traverses, Safety Factor, haul systems, and basic rescue**

The main focus in this guide is about how to create a safe environment for training others. The Training set ups section outlines a few important considerations when setting up a climb training area and how to set lines that a climber can easily be belayed back down to the ground on in case they panic. The traverses section covers elements about setting up traverses in a safe manner with a focus on imparting information about the exceptional loads that a traverse can generate. Knowledge about creating efficient haul systems can not only make getting platforms and gear up into the canopy much easier, the knowledge might also enable a climber to affect a rescue of a person much larger than themselves. The Basic rescue methods laid out in this guide are just that. Basic. They focus on how to get a climber off a line and onto solid ground assuming you only have the most basic gear available.

This guide like all EF!CG guides are written with the assumption that the person reading the guide will be using the methods within a forest scenario. Most if not all the information within can easily be applied to non-forest situations but, for example, the training set ups section is written assuming you have trees to put lines in and are not using scaffolding or some other sort of artificial structure.

### **Training set ups**

Putting on a training? Well, make sure to have copies of all the EF!CG guides on hand for people to review. The first consideration is location. From a tree in a backyard to a dedicated climbing camp, there are a few things to keep in mind when selecting a site. Aside from the obvious need for large trees some other things to think about are:

- What shape are the trees in? Nice and healthy or are there dead branches, a broken top, sloughed off bark, or any other sign of poor tree health?
- Are there enough trees in close proximity to meet your needs? Planning traverse routes, and other obstacles before setting up will make your life easier. Also you don't want to have trees spaced out so far that the trainers can't keep an eye on everyone.
- How hard will the trees be to get into? Can you get shots off with a bow or will you

have to use throw bags or girth hitch up the trunk?

- If you are at a larger gathering, where are the trees in relation to paths, parking lots, gathering locations? Climbing areas can be flashy and cool so you might want to have the climbing area right up front so people get excited when arriving, or you might want to have the climbing area tucked away somewhere so climbers don't get distracted. Also, cops love to come and check out climbing areas so if you anticipate a police presence be aware that they will be making their way over to the climbing area and will want to talk to someone. Climbing trainers need to be comfortable being in the presence of police. You can't run off and hide if someone is up a line and is depending on your instruction.
- Location of medics. Just in case an accident happens know where to go to get help.

Once the location has been picked it is time to get out your gear. Here are a few pointers when dealing with gear:

- Having a gear tarp helps out a lot. A tarp large enough so that all the gear fits on one half of it is nice so in case of rain or the need to get the gear out of sight (i.e. cops) you can just fold the tarp in half.
- Know who's gear is what. Make preset harnesses and don't let people mix and match. If people have brought gear to share with others make sure it is labeled in some way. Colored tape on all ropes and gear is one way to do this. Make sure people know that if they bring gear and leave it at the climbing area, there really is no guarantee that they will get it back. But if it is labeled then their chances are much better. It is always a good idea to have a gear clerk. Someone who makes a concerted effort to keep track of what gear there is and who has what. Checking out racks (a complete gear set up) is a good way to do this if enough gear is available. Carabineers have a tendency to walk away, not because of thief but just absentmindedness.
- If people are bringing in gear for people to use, you need to have an idea of what the history of the gear is. Ideally you will be using all gear that you know, and you know the history of but the reality is, that resources are hard to find so borrowed gear might need to be used. The same goes for gear people are using themselves. Just give a quick peek at the gear a person pulls out of their bag if they intend to use it to go up one of your lines. Make sure that it is gear you are comfortable with them using.
- Don't leave gear unattended. Your own back yard, not an issue. At a camp with a bunch of unknown hippies... issue. Aside from theft, a concern is that someone you don't know might grab up a harness and scamper up a tree and start doing some unsafe shit.

# ROPES

There are two basic ways to anchor a rope. Anchoring the rope up high in a tree and anchoring a rope down below. Volume 2 goes over some considerations when anchoring ropes. When doing trainings, there is a real big advantage to having ropes anchored on the ground. If a person panics and koalas (grabs the tree and stops responding or is unable to move) and needs to be lowered down, you have access to the anchor point and can easily belay them down. If the anchor is at the top then someone will have to go up after them.

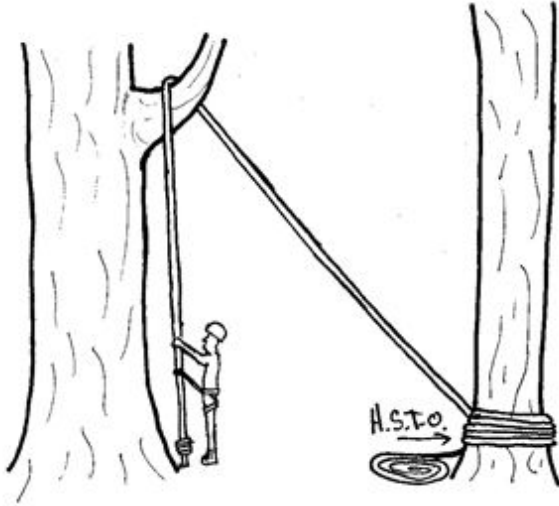
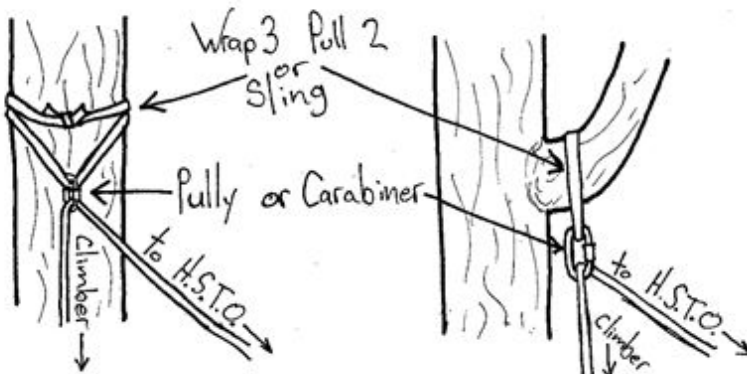

Figure 1. The climb line is running over a nice big branch and is anchored at the ground with a High Strength Tie off (H.S.T.O.). Note that there is extra rope after the anchor.

For basic, first time climbing, either the rope should be anchored at the ground or there should be two lines in the tree so a trainer can go up and direct the trainee at the same level or, has their own rope to be on to effect a rescue. Avoid as much as possible sending a new climber up a single line in a tree that is anchored up high in the tree. Figure 1 illustrates anchoring the climb line at the ground with it looped over a branch. If using a branch, keep in mind that the weight of the climber is effectively doubled at the

branch. If you are not confident in the structural integrity of the branch or if there are no

branches suitable for use then the other option is to set an anchor point with a wrap 3 pull 2 or sling and have the rope run through a locking carabiner or potentially a pulley. Figure 2 shows the basic



set up.

Make sure that the High Strength Tie Off (H.S.T.O) has enough rope coiled after the anchor so that a person that has climbed all the way to the apex of the line can still be belayed down. Don't just let the extra sit in the dirt. Either coil it up and hang it

**Figure 2. Two possible rigging solutions. Even if you have a branch, it can be a good idea to use a sling in the case someone needs to be belayed. Belaying a climber over a branch could easily cut into the cambium layer of the tree.**

somewhere or put it in a bag. Also you want to wrap down with your H.S.T.O.. Meaning you want the rope to come down from the tree and come to the top of the wraps so it does not cross itself.

If someone does get stuck then getting them down is a simple matter of untying the H.S.T.O. and take out the wraps around the tree until one or two (two if the tree is skinny or has smooth bark) wraps remain and simply belaying the person down. Remember, you the trainer have the say when deciding when someone gets belayed down. Even if a climber does not want to come down but you feel it is time, for whatever reason, you can make the call.

When setting up a training area there needs to be a small handful of core trainers that have absolute veto power over anything climbing related. Don't be afraid to 86 someone from the climbing area if that person is creating an unsafe situation and don't let anyone talk you into letting something happen if you are not comfortable with the scenario.

One good aspect to include in a training set up is a series of challenges for a climber to tackle. There are several options in setting up challenges and one of the best and easiest is to go across a traverse. A short list of good challenges in approximate order of difficulty is:

- 1) Simply go up and down a rope.
- 2) Cross a very low, short, and tight traverse (low meaning you can step onto it from the ground)
- 3) Go up a rope and cross over a knot in the line.
- 4) Cross over a knot coming down a line.
- 5) Go up a rope and transfer to an adjacent rope and come down.
- 6) Go up a rope, cross a medium and lose traverse and come down a different rope.
- 7) Go up a rope and pass a wide section (3 feet or more) of "bad rope" without transferring over to the tree.
- 8) Go up a rope and transfer to the trunk, untie your climb line and reset it over a branch to double line descend to retrieve the rope from the tree.
- 9) Go up a rope, reset your climb line higher and come down. To reset the line the climber can either assist climb using lanyards (lobster claws or monkey tails are

common terms for lanyards) around branches as safeties, or girth hitch up the trunk, or throw the line over a higher branch.

- 10) Create a haul system in a tree to raise a weight, possibly another climber if the raiser can find someone that trusts them enough.
- 11) With a partner create a haul system to get a weight (another climber) from one tree to the next without touching the ground.

These are just a few suggestions and feel free to let your imagination go wild with scenarios to test your budding climbers. The only restriction on the challenges should be that at all times proper safety protocols should be followed. Namely maintaining two points of safety at all times.

## Traverses

The most important thing to keep in mind about traverses is angles. As discussed in volume 2, angles can exponentially increase the weight applied to a traverse. For a more in-depth discussion on the physics of rope refer back to volume 2 but a quick reminder:

Assume a traverse is so tight that when a 150 pound person is in the middle of it, the angle of the traverse at the nadir is 170 degrees. (figure 3 depicts our hypothetical). That 150 pound person is creating a load of 17,250 pounds at each anchor point! There is no way without some serious mechanical advantage to create a traverse that tight but keep in mind the physics.

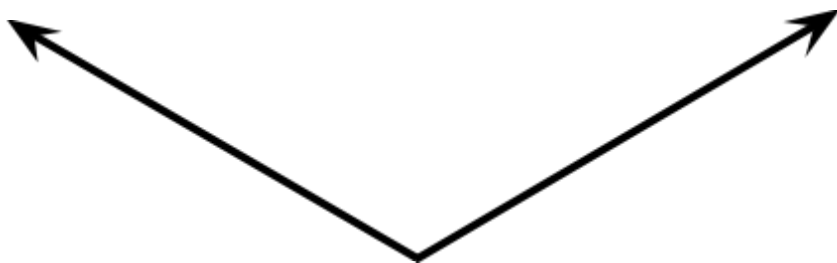

Here is a handy guide. This is a 120 degree angle. If a climber is in the middle of this line then they are sending a force equal to their weight to each anchor. If the angle is larger, then they are sending more than their weight to each anchor.

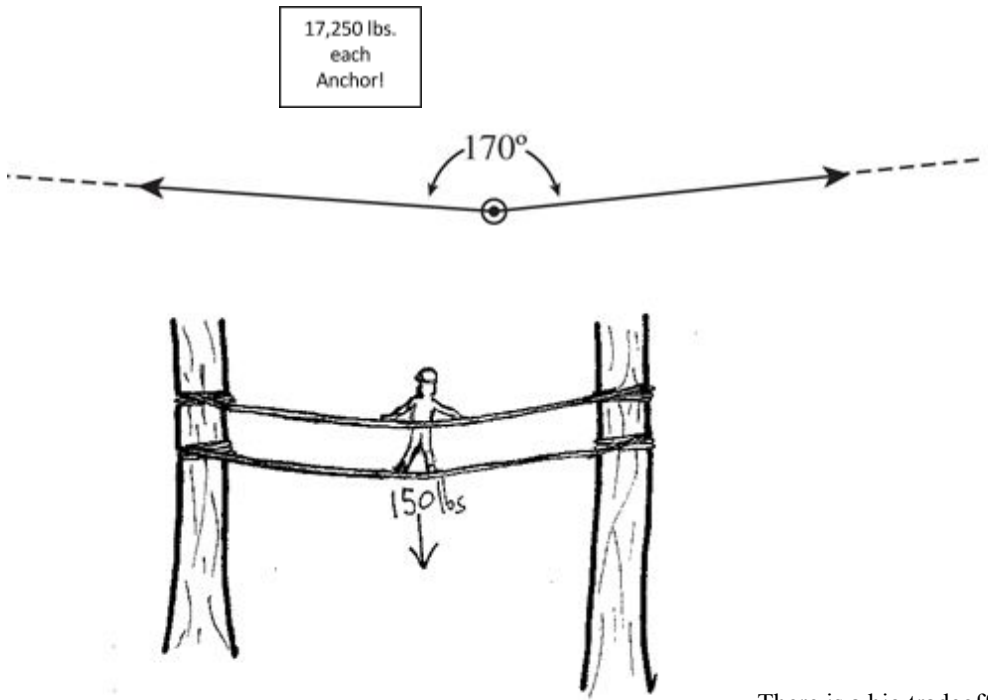

**Figure 3. DANGER! Our 150 pound person is generating 17,250 pounds of pressure on each anchor point if this were to be a 170 degree angle.**

There is a big tradeoff between ease of crossing a traverse and safety factors. The tighter the traverse is, the easier it is to cross but

the greater the forces are that are generated. Not only do you have the weight of the climber to worry about with a tight traverse, you also have the swaying of the trees to consider. A tight traverse will essentially be shock loaded every time the two trees between it blow in different directions.

To address this issue several solutions have come about. From simply ignoring the physics and creating tight traverses to having prusik “breaks” at each end so the traverse can be temporarily tightened. The best solution is to teach people to cross loose traverses. The problem with having prusik knots at each end is you are still putting an excessive load on each knot and the potential for them to slip or break is much greater than when using them to climb with. The one exception I make to the loose traverse rule is when setting up a low traverse for people to get comfortable on. A low, short, and tight traverse is a good training tool and a fun exercise for people just learning to climb.

To tie a traverse a H.S.T.O. should be used at either end. This is because as its name implies, a high strength tie off is the strongest way to anchor a rope. This is because there are no knots in the line taking any of the load. The load is transferred into the wraps instead. With traverses it is especially important to use a steal link or carabineer for clipping the end of the H.S.T.O. back to itself. With traverses is good to have just a little tension on the carabineer at

the tie off and you want to avoid any potential rope on rope friction points.

Figure 4. A H.S.T.O. Three wraps is generally good for an anchor. Notice that you 'wrap up' when tying for a traverse, the opposite of 'wrapping down' for a ground anchor.

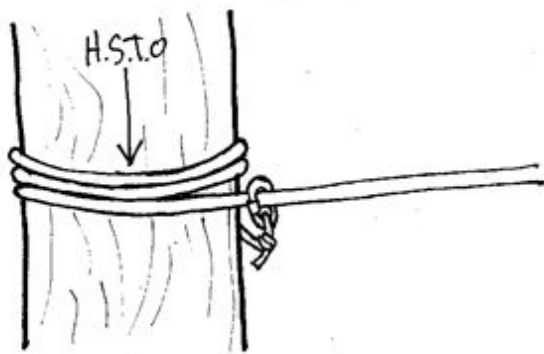

Wrapping a rope multiple times around a large diameter tree can be a major pain in the ass. The first wrap will be the hardest. A few tricks are to scamper as far around the trunk as your climbing line allows and trying to toss the end onto a branch or something so that you are able to swing around to the other side and hopefully reach around to grab it. You can also try "tapping". This is only an option if there is little to no vegetation in your vicinity. Give yourself 3 feet or so of rope and swing the rope around the tree tapping it with the end. Now quickly swing the rope around the other direction allowing some rope to come through your hand lengthening the rope you are swinging by a foot or so. You can swing the rope back and forth a few times tapping the tree until hopefully you have enough rope to reach all the way around the tree. Be careful trying to catch the end as it comes flying around the tree as it can be quite painful if it jams a finger.

a

Once you have the initial wrap done you can use handy trick to get a second and third wrap done. Figure 5 gives you an idea what to do. Make a bight and tie a butterfly knot on the running side of the line and tie the end of the line into the butterfly making a loose loop around the tree. Then twist the loop

around the tree multiple times and you have just completed three wraps with little effort. Make sure to untie the butterfly and to properly finish the H.S.T.O. by tying an eight on a bight with the end and using a carabiner or steel like to clip the rope back onto itself. The only drawback to this technique is that it is very difficult to keep your wraps tidy and uncrossed.

For a traverse you need two lines. You can either have the ropes on either side both on the same side of the tree. Both ways have their advantages and disadvantages. Figure 6 is a top down view of a traverse tied on opposite sides of the trees Neither was is the correct way and what is used is generally based solely on the preference of the rigger. Having ropes on the same side of the tree allows the person crossing the traverse to have their arms above

their head and keep a straight vertical line with their body. If doing lines on the same side of the tree you will want them to be a bit further apart than if they are on opposite sides of the tree. You almost want to be hanging just a little from the top rope when you walk across the

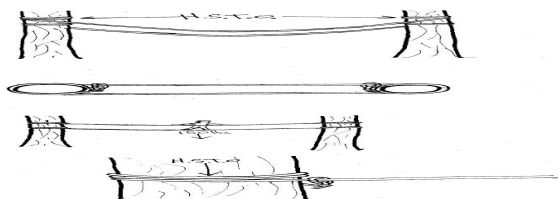

two traverses are on either side of the trees.

traverse. Some people feel that walking barefoot across a same-side traverse is the most secure felling way to cross a traverse. Having the ropes on either side of the tree allows a person to be able to lean into the top rope a little and can add stability when crossing shorter traverses but could also decrease stability when crossing long traverses. One advantage to traverses on either side of the tree is that when crossing with a pulley you have some space between the lines which can make your life easier. For the rest of the guide when referring to traverses we will be talking about opposite side traverses as they are the most common at this point. When a traverse is done it should be loose with no knots anywhere in the load bearing system. Figure 7 is what a well tied traverse on opposite sides should look like in regards to the amount of slack present.

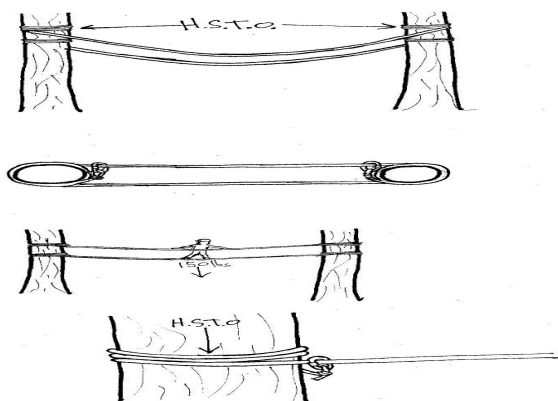

Figure 7. An idea of what a correctly tied traverse should look like.

What types of rope are acceptable when tying traverses? The key points to keep in mind are that the forces acting on a traverse are much greater than the forces acting on a normal climb line. In an attempt to be able to effectively defend large areas of land with limited resources it is not uncommon for polypropylene rope (truck rope) to be used to tie traverses. Necessity can often dictate the materials that we use in a campaign but making informed decisions is critical. I have seen many poorly tied traverses, with multiple knots in the system, and

tied with small diameter truck rope, that have been pulled tight and I have yet to hear of one of these traverses breaking under the load of a climber, **BUT!** that does not mean that they were not incredibly unsafe. It is more by luck than by design that more traverses have not broken under load. The best rope to use is climbing grade static line for the load line and climbing grade dynamic line for the safety line. Static for the load line because dynamic will stretch considerably and will make crossing the line much more difficult. Dynamic for the safety line because if the load line does break, having the shock absorbing characteristics of dynamic for the safety line will make the fall less jarring and shocking for the system.

If you feel you need to place a traverse and don't have enough climbing grade line and are willing to use much less safe polypropylene rope then use the truck rope for the load line. This may seem counter intuitive as the load line has more weight placed upon it but if the load line were to break you will be shocking the safety line and the safety line will be much more likely to hold if it is climbing grade line. This being said, traverses should not be double truck rope. This would be a campaign decision to make but climbers should be made aware of just how unsafe a double truck rope traverse is. If truck rope is being used a few considerations are: 1/4" truck rope is cheap and weak and should never be used under any circumstances. 3/8" truck rope is better but still should not be used for traverses. Truck rope 5/8" and bigger is obviously going to be stronger but most climbing pulleys are too small to accommodate truck rope bigger than 1/2".

Pulley traverses Vs. Walkways. There are two main ways to cross a traverse, attaching a pulley to the upper line and a safety lanyard to the bottom line and crossing via pulley or to standing on the bottom line and walking across the line. I prefer pulley traverses as it is easier to cross a slack traverse using a pulley and walkway traverses generally need to be much tighter and thus much more unsafe. Either way, when tying a traverse you only want about 3 feet between the top and bottom line on the tree. Once you get into the middle of the traverse there will be considerably more space between the two ropes.

In a pulley traverse the top line is the load line and the bottom line is the safety line. Refer to figure 8 to see what each step is. To transfer from a climb line to a pulley traverse you want to be high enough on the climb line that you are able to easily clip your pulley onto the top line (C). You should still be able to clip your safety lanyard onto the bottom line (E) from the same spot on the rope. At this point it is a good idea to tie a prusik with a sling on the top line behind the pulley (B). Use a shorter sling for this application. This sling serves two functions. First, it will keep you near the tree you are leaving from until you are ready to

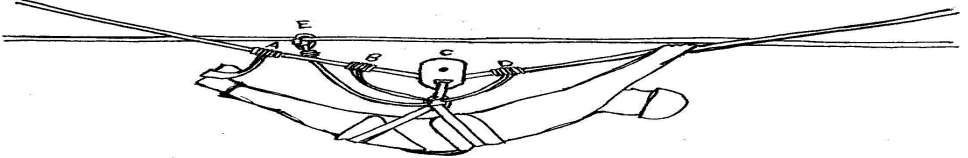
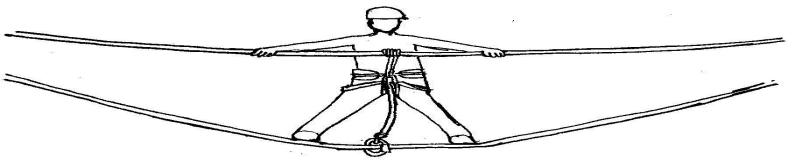

cross the traverse and secondly, if your lead line were to break, it will synch down on the line and not just slide off keeping you attached to the line. Don't put this line into the same carabiner as the pulley as you will need to remove it once you get to center of the line. Now you can just "reverse prusik" down your climb line until your weight is on the traverse. Detach yourself from the climb line and clean the line of your slings. You should now have your pulley (C) on the top line with a prusik behind it (B) and a second safety lanyard on the bottom line (E). Look at figure 8 to reference the gear you should have on the line when

**Figure 8. Crossing a pulley traverse. Top line is the load line and the bottom line is the safety line.**

starting to cross. You should have points E, B, & C on the line but not A & D. To get going you should be able to step up on the bottom line just enough to be able to release prusik B and away you go. Make sure to keep a hand on prusik B to have it come along with you and not get hung up behind you.

Once you reach the nadir of the traverse you are going to want to add a prusik in front of your pulley (D) and remove the prusik behind it (B). You are going to need to pull yourself the rest of the way across the traverse and having a short prusik at D can act as a progress capture. If you use a short sling and keep the prusik at D a little loose, the pulley itself can advance it and you won't have to worry about advancing it yourself. If the angle of the traverse is too severe to be able to pull yourself across then adding a sling at A to be used as a foot loop can be very helpful. In this manner it is possible to cross a slack traverse effectively and in the safest manner possible.

A Walkway traverse (Figure 9) has the load line as the bottom line and the top line is the safety line. To transfer from a climb line to a walkway a good way is to get to a point on the climb line where you can sit on the bottom line and get most of your weight onto the line. Once sitting on the bottom line you can attach a sling with a prusik onto the top line and your safety lanyard onto the bottom line. You are using a prusik on the top line in case of your line breaking; you will not just slide off the end. Once you have attached yourself to the lines you can then take off the foot loop from the climb line and then stand up on the walkway to unclip and remove your lead loop from the climb line. It may help you tuck the top line of the traverse into your armpit to free your hands. Standing on the bottom line you can shimmy

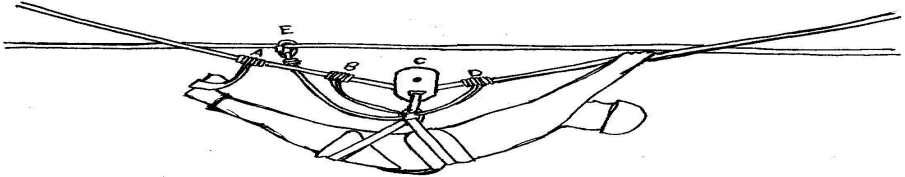
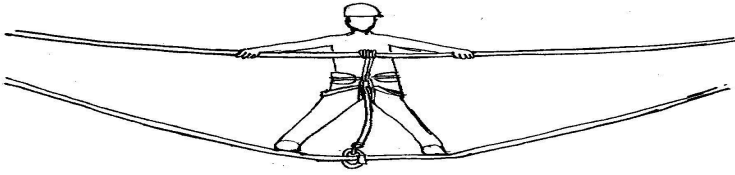

Figure 2. Crossing a walkway. Top line is the safety line and the bottom line is the load line.

your way across the traverse keeping your safety lanyard between your feet. This can be exceedingly difficult on a slack traverse.

## Safety Factor

The Safety Factor is a number to represent how much a system is over engineered. Meaning that if a system has a Safety Factor (SF) of 5 then it can safely hold 5 times the weight being applied to it. A few examples of SF in the industrial world is the National Fire Prevention Assoc. requires a safety factor of 7 for all non-life carrying systems and a SF of 15 for all life carrying systems. Ideally in our climbing world we should have a SF of at least 10 and avoid dipping down below a SF of 5.

So how to figure the SF for your system? The SF is a simple equation

$$\text{Safety Factor} = \frac{\text{System Strength}}{\text{Load on System}}$$

When dealing with rope, the value you are concerned with is not the tensile strength but rather the minimum tensile strength. This is a bit confusing as you will likely never see the minimum (or yield) tensile strength listed on a rope. The difference is that the tensile strength is the load at which a rope will break but the minimum tensile strength

is the load at which a rope will begin to deform. To confuse matters further, some ropes may list the minimum tensile strength as the tensile strength. To estimate the minimum tensile strength of a new rope, reduce the approximate average tensile strength by 15% (Cordage Institute defines minimum tensile strength as two standard deviations below the average tensile strength of the rope but unless you have all breakage data and a way to produce summary statistics... just use the 15%). If you have a brand new 10.5mm static rope with a listed tensile strength of 6,500lbf then you should use  $6,500\text{lbf} \times 85\% = 5,525\text{lbf}$  as your value for deriving the SF. When deriving the SF for a system you must take into account any point that degrades the strength of the system (i.e. knots, angles, age, etc.). The SF for an old rope will be less than for a new rope in the same system. How much age degrades SF is dependent on the use the rope has seen. Knots in a system are not cumulative in determining the SF. You are only interested in the knot that degrades the strength of the system the most. Calculating the SF for a system can be very difficult in a complex rigging scenario. The trick is to follow the weight of the load through every bend, knot, and redirect to determine the weakest point of the system Figure 10 has some examples listed. Also you must account for

**Figure 10. SF examples assuming a new 10.5mm rope and a 200lb climber.**

any potential fall factor in the system. The fall factor is the length of the fall divided by the length

of the rope. There are a few other elements that come into play when considering the fall factor, such as the amount of rope stretch but for our purposes we should always be dealing with a very low Fall Factor because in forest defense, *no one but an irresponsible asshole ever climbs above their anchor*. A fall factor of 2 is normally the greatest possible value you should encounter. If there is the potential for a climber to take a fall you need to consider the amount of shock that fall will put on the system. While the Breaking strength of polypropylene ropes might not appear that drastically different than climb lines of similar diameter you do not use the 15% estimation for truck rope. Instead, you should use the printed safe working load of the rope which is about 10% of the breaking strength. Figure 10 shows a few examples of figuring the SF for various scenarios assuming you are using the aforementioned 10.5mm rope with a minimum tensile strength of 5,525lbf, a 200lb climber, and a potential fall factor close to 0. Traverses are much more susceptible to shock loading due to the angles involved so a SF of 15 or more should be used with a SF of 10 being the minimum.

## Haul Systems

Knowing how to set up a haul system with mechanical advantage is incredibly helpful when pulling platforms up trees, erecting tri-pods, getting water jugs up to a sit, and could be critical to enable a rescue. The very basic idea is to distribute the weight of an object to multiple lines. A system that halves the weight of an object is called a 2 to 1, a system that reduces the weight of an object to a third of weight is called a 3 to 1, etc. A 2 to 1 not only reduces the weight by half but also doubles the amount of rope you must use to pull up an item. A 3 to 1 triples, a 4 to 1 quadruples, etc. The most common misunderstanding about a haul system is that more pulleys = more mechanical advantage. This is only true if the

pulleys are put in correct locations. Figure 11 is a system with 2 pulleys but zero mechanical advantage. To create an advantage the rope must alternate between the load and an anchor. The anchor does not have to be the same but it does have to go back to the same load. In figure 11 the rope goes from load to anchor to anchor to hauler. In this and all illustrations, angles and friction are not accounted for to ease the teaching of the principles but in reality they would play a big part in what forces were being generated. In figure 11 you can also see that the redirects have also doubled the load on each anchor point.

**Figure 11. A system with multiple pulleys but no mechanical advantage.**

by putting a pulley in the mix to redirect the direction of pull you have 1

For a basic 2 to 1 system the rope goes from anchor to load to hauler. In the next figure (12) the rope goes from anchor to load to anchor to hauler. The second anchor point does not increase the mechanical advantage but having it there might make hauling of the load easier. Also pay attention to the weight distribution on the anchors. For a 3 to 1 the rope goes from load to anchor to load to hauler as shown in figure 13. In odd numbered systems the rope originates at the load and for even number loads the rope originates at an anchor. There is no limit to the advantage you can create other than what is feasible with the amount of gear that would be required and eventually frictional forces. There are pulleys that are designed for use with haul systems that have multiple wheels next to one another and an anchor point provided at the bottom.

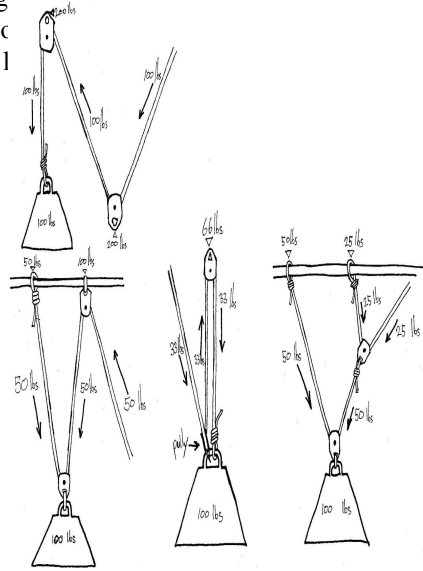

**Figure 12. A 2 to 1 system with an extra pulley thrown in for ease of hauling.**

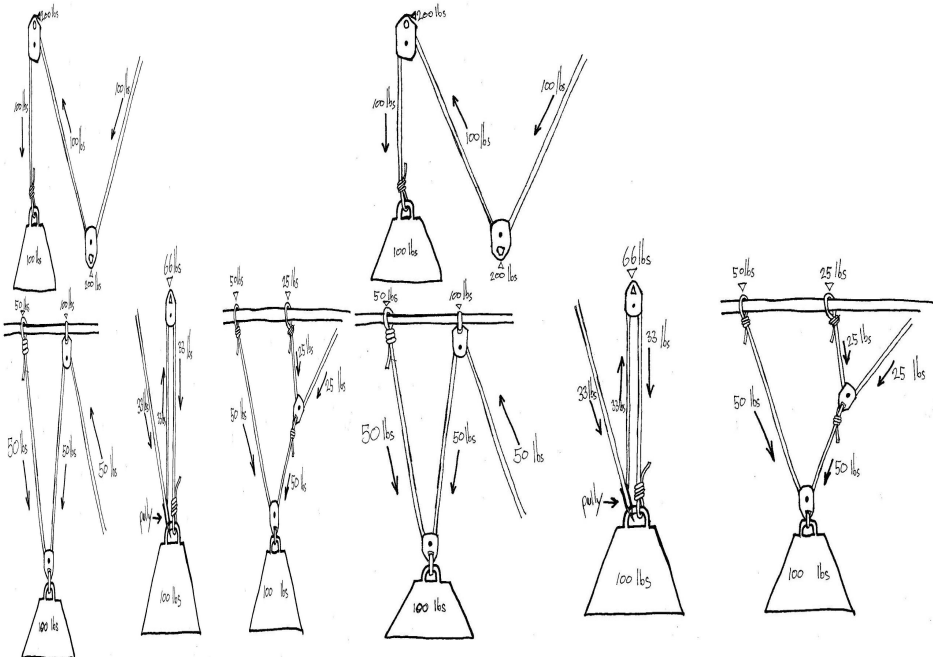

**Figure SEQ Figure \\* ARABIC 2. Two, 2 to 1 systems used in tandem**

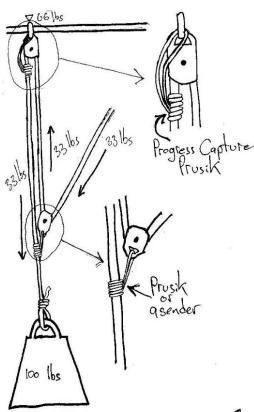

To increase the amount of advantage you create you can make compound systems. In essence you are creating a haul system to haul another haul system. In Figure 14 there are two 2 to 1 haul systems put in tandem to ultimately reduce the weight of the load by 75%. The obvious issue with making a compound system is that once the pulley on the first system is raised up to the anchor of the first system you can't go any higher. You can address this limitation by integrating progress capture prusiks into your system.

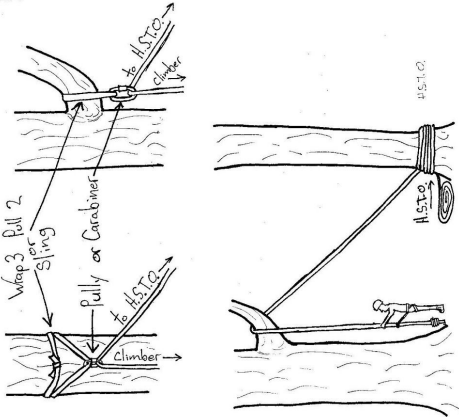

The best place for a progress capture prusik is at the first pulley in a system. You can also use a prusik to shorten the rope needed to create a haul system. Instead of running the rope all the way back to the load you can use a pulley or carabiner attached to the line with a prusik or an ascender. The action of hauling the load would look like: hauling

until the two pulleys are next to each other, then allowing the progress capture pulley to hold the load as you readjust the lower pulley further down the line, and repeat. The potential applications are limitless. The first that comes to mind is hauling a 5 gallon water jug up to a tree sit 50 meters above the ground. Also, this is a system that can be used to haul up a climber if they need assistance once they are dangling over the side of a bridge using their own rope.

## Basic Rescue

When considering how to rig a rescue set up, no two situations are going to be exactly the same. You have to be able to improvise with the gear you have available. This part of this guide is only going to cover two possible scenarios assuming that you only have access to very basic gear. This is also trying to cover what could be a complex scenario in only a few pages so it will probably be confusing at first. Try to have some rope handy so you can try to set up a rig as described for each scenario. The first scenario is hauling a climber back up to a platform. This is pertinent to actions where a climber is descending from a height most likely to deploy a banner. The second scenario is if a climber is stuck in a tree, both conscious and unconscious. What is not going to be covered is any medical treatment aside from basic considerations if dealing with an unconscious climber. A major consideration is harness pathology. If a climber is unconscious then the blood in their extremities can be prevented from circulating. If a person has been hanging for a while then you should avoid allowing all stagnant blood from flooding back into the system all at once. Lifting one leg at a time slowly could help with getting the blood flowing again and avoiding

a shock to the system.

If a climber needs to be hauled back up to a platform the fastest way is to grab hold of the rope and haul them up. However unless you are very angry and your name is Bruce Banner you are unlikely to be able to simply pull a climber up. Aside from the physical limitations, you also have to consider what happens if you were to lose your grip and the climber falls down shock loading the rope and potentially doing more harm to the climber. Pulling someone up back onto a structure with a haul system is easy with a little practice.

In actions where a climber is going over an edge the best anchor to use is a H.S.T.O. with extra tail left above. This allows the climbers buddy on top to be able to haul them up by simply securing the rope below the H.S.T.O. using ascenders or a couple of prusiks, untying the anchor and setting up the 3 to 1 haul system described in

the haul system section, to get them back up top. If you have 20 feet of tail, two slings for prusik minders, two carabiners to be used instead of pulleys and one more sling for the first anchor point you are good to go. Aside from the basic haul system that can be used to haul a climber back up to a bridge as just described, what if the climber over the edge didn't use a H.S.T.O. to anchor themselves? In that case you can start hauling them with all the same gear you would have needed to effect a rescue in the first instance plus a rope of your own. If your rope is long enough you can set up the 3 to 1 with a progress capture prusik and send the end down all the way to the climber with an ascender with a weight clipped onto it. The ascender will go all the way down to your load (the climber in distress) and you can just haul away. If you don't have a rope long enough or an ascender and a weight you can rig a 3 to 1 system that is attached to the their anchor knot (assuming a figure 8) with a rope that is as short as 5 or 6 feet and slowly work their line up by hauling the 2 feet or so your rope will allow,

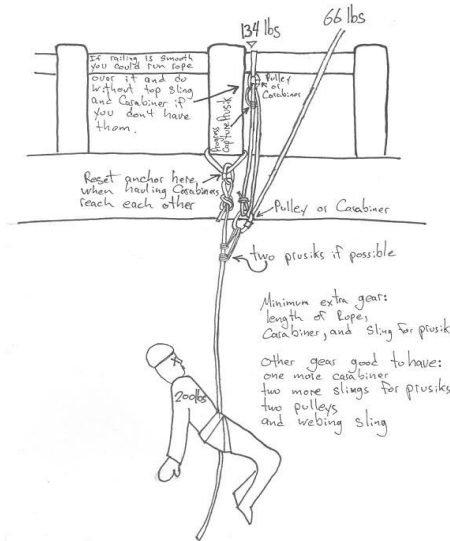

**Figure SEQ Figure \\* ARABIC 4.** If you don't have enough rope from the climbers anchor to create a haul system you can make a system to attach to the climbers line with minimal extra gear. The forces labeled in the figure don't take into account friction or angels but they convey the idea of the haul system.

securing their climb line, resetting your haul system lower on their line and starting again. Slowly raising them up 2 feet at a time until either you have enough of their rope to reset the haul system using only their rope or until you have gotten the climber in distress all the way back up to the bridge. Simple. Figure 16 illustrates the basic idea. If the basic gear isn't available you will have to improvise as needed but there are too many possibilities to be able to cover them with any depth here.



The mostly likely scenario that a climber will need to be rescued is at training when the climber panics and goes koala. As described earlier if the climb line is anchored at the ground then belaying them down from the ground is the best option. If that isn't an option but there are two lines in a tree then going up the second line and belaying them down is the best option. The first consideration is whether the climber is coherent or not. If the climber is coherent and just needs help down then lowering them by themselves shouldn't be a problem. If the climber is unconscious then you might have to go down with them if there are branches to navigate around. Lowering them by themselves might be an option if the way down is clear and there is someone at the base to receive them. For brevity's sake we will assume the climber in the tree with two lines can be lowered by themselves and an example of how to go down with a climber will be presented in the scenario that the climber is on a single line in a tree. The basic principles to lower them solo or tandem can be applied to either scenario.

If there are two lines in the tree then getting up to the climber is as easy as ascending the second rope, but what if there is not a second line in the tree. There are two options at this point. You can either set another line in the tree or you can go up the climber's rope under them. The best option is to set another line in the tree by whatever method available. If throwing shot bags or shooting arrows into the

tree, you obviously want to take care not to hit the climber you are trying to rescue. If for whatever reason you can't set another line in a tree that the climber in distress can be reached from then you are stuck going up their line after them. There are several very important considerations before going up a line after another climber. First, if the climber in distress took a lead fall and shock loaded their rope then you must assume that the rope has been severely compromised and assume that your added weight could cause the rope to break. If a lead fall has happened, the only possible justification for going up the rope is that you are

convinced the climber will suffer severe injury if you don't and you are convinced the rope won't break with your added weight. Secondly, if you can't see the climber from the ground and know that their line is clear and not wrapped around one of their body parts then you should not go up the line after them. Thirdly, you need to consider the fact that by climbing on their rope you are cutting the Safety factor by half and that might create such an unsafe situation that the risk to your own life is unacceptable. In short, you want to avoid climbing up a rope after someone at all costs but it might be unavoidable in certain situations.

So the situation is a climber is coherent and on a single line in a tree next to the trunk. You need to get up even with the climber and on a second line. You can either girth hitch up the tree or set another line by some other means or potentially go up their line after them if it is safe and then transfer to the trunk once at their height. Figure 17 shows the second climber on a line that is too short to reach the ground. Their line could have been set by either girthing or going up the climber's line after them. Once you are on your line you need to set an anchor above both you and the climber in distress. This can be just a sling and a carabiner. This is going to be your belay redirect. If you have access to additional ropes that are long enough to easily reach the ground from the height you are at then use one of those lines for your belay line but assuming you don't have access to extra rope you can use the end of the climber's own rope to belay them down. Take the end of their rope, untie any stopper knot that is at the end and run it through the belay redirect and attach the end to the climber's harness. Then put your own belay device on the line along with a prusik safety. In figure 17 the belay device is an ATC which is the belay device recommended but an eight will work as well. Things to consider at this point, first, you don't want your safety prusik long enough that it will cross over the belay redirect, and second, you will be belaying the climber down from your own harness so take into consideration if there is a large weight discrepancy you could be pulled up as the climber goes down. If there is a concern a good idea is to use a lanyard from your harness wrapped around the trunk or a branch below you to hold you in place. Once you have the belay line set up, remove the foot ascending loop of the climber from the line. You are now ready to belay the climber down expect for the one weighted prusik that is holding the climber up. Getting the climber's weight off this weighted prusik is the single most difficult aspect of affecting a rescue in this situation.

There are 3 main ways to get a climber off of the weighted ascending loop. The easiest is if they are coherent to have them use their own foot loop or to use a foot lock in the rope and get the weight off the prusik themselves. The second option is for you to lift them up to get the weight off. If you are strong enough you might be able to just muscle them up but more than likely, you are going to need to put together a haul system that will enable you to lift them. Thirdly, and this is the option that should only be used as a last resort, is to cut their prusik. This is a bad idea and should only be done with extreme care. If you are cutting the line then you should use scissors but most likely you will only have access to a pocket knife. Rope under pressure cuts very easily and suddenly so you need to consider that you will have an exposed sharp edge in the direct vicinity as life holding ropes and once you cut the line there will be a sudden fall for the climber that could easily send them falling into the knife and either cutting themselves or bumping the knife into a rope and cutting into it.

Realistically, you are going to be slapping together a haul system to raise the climber up. All you need is a length of rope about 6 feet long. Figure 15 demonstrates how to rig the simple haul system. The shaded rope is the rope for the haul system. You can use either a knot at the end to fit your foot into or a foot loop attached to the line to step onto the line and

lift the other climber to remove their ascending loop. This loop does need to be removed and not just loosened on the line. Don't bother trying to untie the prusik from the line at this point, just unclip it from the climber. Once their prusik is off the line their life is literally in your hands. IMPORTANT, you need to detach the haul system from the climber BEFORE starting to lower them down. If you leave the haul system attached to the climber it might just slip through the carabineers to harmlessly dangle or it might catch on something and then you will be in a very bad pickle.

Now the climber is on the ground and everyone is happy. If the option for just lowering the climber by themselves isn't available you need to be able to rig a system where you descend with the climber. First step, get to the climber. If you are going up a rope after someone you should try and get the rope to not be between their legs. This isn't a safety issue but rather a "getting WAY to familiar" issue. If the rope is between the upper climbers legs you will have to pass your prusiks past their crotch and for a step or two up the rope your head will be right between their thighs.

After passing the other climbers crotch go ahead and get between their legs with your knees on their butt. Being in this position will make attaching them to your harness with a carabineer much easier. First, however, you need to set a haul system that will allow you to get them off of their lead loop. It might be possible with your knees below their butt to bump them up enough that when the time comes to loosen their lead prusik you can simply do that but if that isn't something you can do you will need to set up the haul system. Using a carabineer and a sling, tie a prusik as high as you are easily able to with the carabineer hanging from it. Take the end of the rope you are on and thread it through the carabineer then down to a carabineer on the climber in distress's harness, and then tie it onto the carabineer you threaded it through. A bowline is a good knot to use at this point because you are going to need to be able to easily untie it before you can descend.

Attach the other climber to yourself with a carabineer between your two harnesses at a load bearing location. Once you have them attached you can take off their foot loop. Attach your belay device in the same manner you normally would. For this type of rescue you will be

belaying both yourself and the other climber so an ATC-XP with the friction ridge is strongly advised as with an eight the extra weight could make descending under control much harder. Take off your foot loop and attach it to the climb line at a point below the upper carabineer as high as you can and still be able to put your foot into it. Figure 16 illustrates the position you should be in now. It is a little convoluted but follow the climb line from the top. It goes down and has the upper carabineer tied to it with a prusik. Moving down it then has the lead ascending loop of the climber in distress on it, then the rescuers lead ascending loop. Then it passes through the ATC and is dangling down below the climbers in a long loop. On its way back up it has a foot loop tied to it and then it passes through the upper carabineer going back down to pass through a carabineer on the climber in distresses harness and then goes back up to be tied on the upper carabineer.

Now you are ready for the first tricky part. You have to be able to step up into the foot loop and be able to raise the other climber up enough to loosen their lead prusik to slide it down (don't take it off, just slide it down) and at the same time you need to loosen and slide down your own lead prusik. This isn't as hard as it might sound as once you are standing in the loop you should be able to muck about with the knots as much as you want. Before sitting back down make sure to pull out as much slack from your descending device as possible and lock it off with a mule hitch. Figure 17 is an attempt to demonstrate how to tie a mule hitch with an ATC but going online and viewing an animated clip on how to tie the hitch with an ATC will be infinitely more enlightening.

Sit back down and hold your collective weight with your descending device making sure that both your lead prusiks are loose and in no danger of creeping up and getting hung up. You are now ready for the second tricky part. You have to undo your haul system before you can come down. Untie the foot from the rope and unclip the rope from upper carabineer. You also need to untie the bowline in the end of the rope and thread the rope back out from the carabineer in the climber in distresses harness. Once the haul system is taken (you might want to just leave the upper carabineer in place for now) you are ready to untie your mule hitch and descend down the rope. Un"popping" mule hitch might be trickier with the weight of the other climber on the line keep that in mind.

Trying to describe the steps in setting up a rescue rig is very difficult just try and think the process through your own and get a friend to practice. You really don't want the first time you are trying to rescue someone to be when their life is depending on your knowledge and skill.

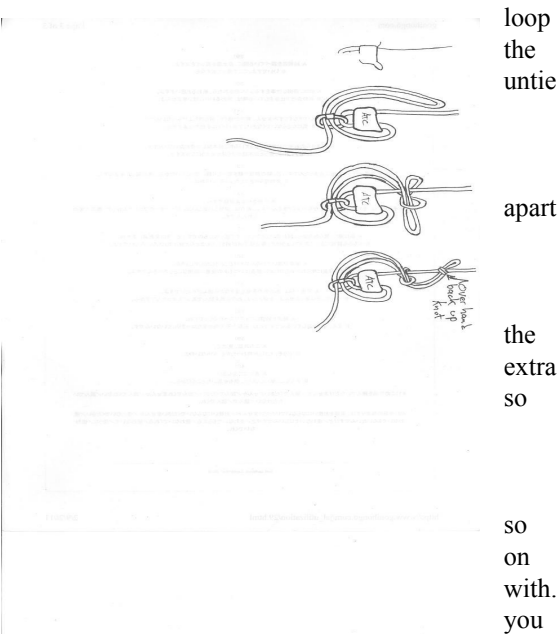

Figure 1 SEQ Figure \\* ARABIC 8. Mule Hitch on an ATC



# Who we are and Why this exists.

We are a group of climb trainers representing multiple bioregions that have come together in order to put forth a series of in-depth orientation packets detailing the safest way possible to climb and rig rope structures in the forest. We are out there putting our lives on the line in order to defend what we believe in. It is of the utmost importance that we stay safe while doing this. It is our hope that in putting these packets out a more universal safety protocol will develop. Knowledge of safe climbing methods isn't something that should only be held by a small minority of "trainers". This is the *third* packet in the series and it is open to amendments and changes. Please copy this and distribute it widely. If you have comments or questions or would like an electronic copy of this packet you can get ahold of us Via E-mail at:

**EFclimbers.net**

**EFclimbers@gmail.com**

# STAY SAFE

This is Vol 3, First Edition. June 2011





